

The Tiger MRL System MK-II

More than just MRL



More than just MRL

Unaccustomed freedom



Your benefits at a glance

The Tiger system is the most adaptable hydraulic drive for lift installations, with or without a machine room.

Small shaft dimensions? No problem.

- Free choice of car and controller
- Shaft pits down to 300 mm
- Minimum shaft headroom as low as 2600 mm
- Maximum car floor area thanks to optimum utilisation of the shaft cross-section
- Proven hydraulic drive with the LRV-1 electronically controlled lift valve
- For high number of travel, also available with frequency control (reduced noise emission combined with high travel performance – and without oil cooling)

Free choice of car and controller

The car's construction is not restricted, and the interior can be fitted out in accordance with customer's wishes. Only the total weight of 1500 kg (TG2-15) or 2500 kg (TG2-25) must be kept in mind.

There are also no restrictions in the choice of lift controller; the preferred supplier's product can be used.

Shaft pits down to 300 mm

A minimum shaft pit of 300 mm (TG2-15) opens up entirely new possibilities! With both old and new buildings, it is no longer necessary to excavate expensive pits. This doesn't just save time; it saves money as well.

Minimum shaft headroom as low as 2600 mm

With a minimum shaft head of only 2600 mm, troublesome rooftop structures are now a thing of the past. This is particularly beneficial for older buildings, where the scope for alterations is very often limited.

Largest possible car floor area

With a minimum wall-to-car gap of 260 mm (TG2-15), the shaft cross-sectional area is put to the best possible use. There is no unnecessary waste of space, and the largest possible car can be installed in a given shaft.

Proven drive technology

Once again, the LRV-1 electronically controlled lift valve, with its load- and temperature-independent operation, takes over one of the key functions.

The Tiger MRL System MK-II

without machine room

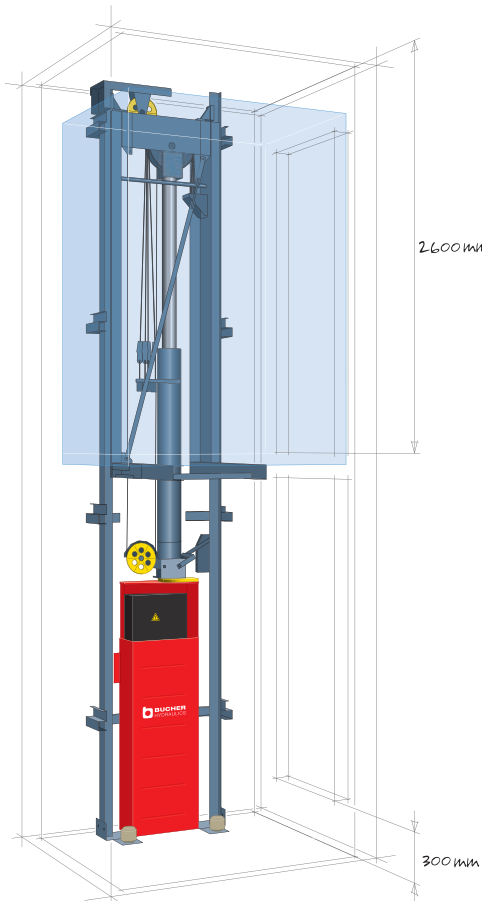

Drive

The Tiger power unit, with proven Bucher Hydraulics components, is positioned between the guiderails in the shaft.

Tiger power unit with LRV

The standard model is equipped with the LRV-1 electronically controlled lift valve. This combination produces outstanding ride comfort, with up to 60 travels per hour without oil cooling.

Tiger power unit with VF-LRV

The frequency controlled, high performance and low-noise drive solution that reduces energy consumption by up to 60 %. It is particularly suitable for high service demands of up to 90 travels per hour - without oil cooler.

External service unit

For a simple control of the lift from outside the elevator shaft.

		TG2-15	TG2-25
Suspension			Side ram 2:1
Max. total weight	kg	1500	2500
Payload	kg	typ. 630	typ. 1000
Weight of support frame	kg	130	167
Max. travel height	m	20*	20
Max. speed	m/s	1.0	1.0
Distance between guiderails	mm	700	1000
Safety gear		Progressive type. Make: Cobiانchi	
Overspeed governor		Make: Bode, with anti-creep feature	
Type of rail		T90 x 75 x 16	
EN-81 conformity		Please refer to the necessary contingency measures detailed in our technical documentation.	

* max 18 m for TG2-15 with total weight > 1150 kg

The Tiger MRL System MK-II

with machine room

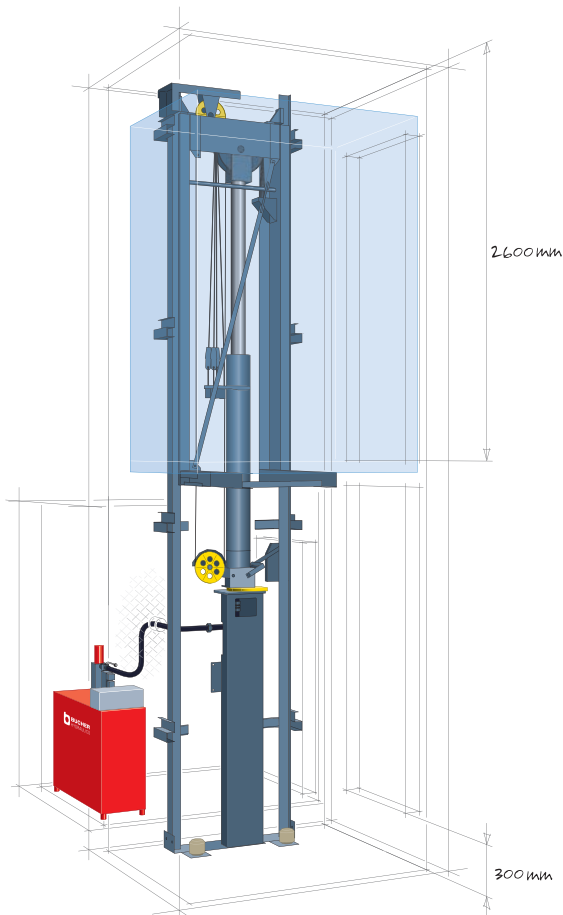

Drive

The following Bucher Hydraulics power units can be used:

Compact Line

The good-value package solution featuring the innovative plastic tank and the C-LRV electronically controlled lift valve for standard passenger lifts.



Comfort Line

The standard power unit with the LRV-1 electronically controlled lift valve offers many options.



Economy Line

The high performance and low-noise drive solution with the VF-LRV electronically controlled lift valve reduces energy consumption by 80%.



External service unit

with emergency-lowering facility, hand pump, pressure gauge and pressure switch



It connects the lift with the outside world and can be positioned either inside the door frame or within the control cabinet (max. 6 m from the manifold block).

This enables a safe and straightforward external operation, even in a case of emergency.

Products

The Bucher Hydraulics range

Bucher Hydraulics offers a wide range of hydraulic lift components.



Electronically controlled lift valves (LRV)

Bucher Hydraulics lift control valves provide unsurpassed ride comfort, irrespective of load and temperature.

All lift control valves are factory preset to the installation-specific parameters. This reduces the on-site installation time to the minimum.

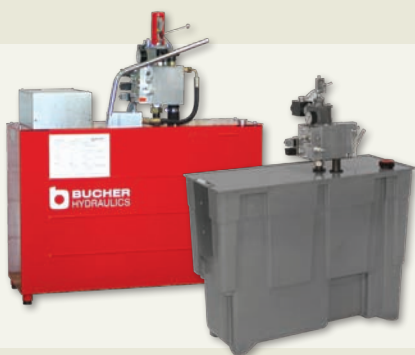

Power units

Compact Line: the good-value package solution with the innovative synthetic tank and the C-LRV electronically controlled lift valve.

Comfort Line: the standard power unit with the LRV-1 electronically controlled lift valve offers unlimited application possibilities and numerous options.

Economy Line: the high-performance, economical, and low-noise drive solution with the VF-LRV electronically controlled lift valve reduces energy consumption by up to 80% in comparison with mechanically controlled hydraulic lift installations.

Frame kits

Pluto: The range of side-ram frame kits is suited for hydraulic passenger and goods/passenger lifts with payloads up to 1600 kg.

Jupiter: The range of tandem-frame kits is suited for hydraulic goods/passenger lifts with payloads up to 6000 kg.

MRL-drive systems (machine room-less)

BERIPAC™: the system offers maximum travel performance with minimum energy consumption.

Tiger: the best system for the optimum shaft utilisation.

Modernisation

MULTIKIT: the route to perfect modernisation of a hydraulic lift drive, without time-consuming and costly replacement of the lift controller.

Cylinders

Versatile, robust and reliable.

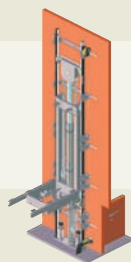
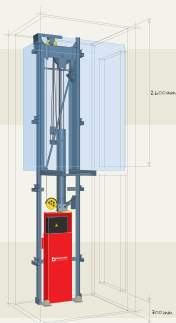

Bucher Hydraulics AG

Industriestrasse 15

CH-6345 Neuheim

Tel. +41 41 757 03 33

Fax +41 41 757 03 17

elevator@bucherhydraulics.com

www.bucherhydraulics.com