



GOODS AND ATTENDANT LIFT

EHM

TECHNICAL SPECIFICATIONS

Contents

1. General description.....	Page 2
1.1. Application	Page 2
1.2. Regulations.....	Page 2
1.3. Characteristics.....	Page 2
2. Detailed description	Page 3
2.1. Drive	Page 3
2.2. Machine	Page 4
2.3. Guiding and installation	Page 5
2.4. Hydraulic installation.....	Page 6
2.5. Electric installation.....	Page 6
2.6. Car.....	Page 6
2.7. Landing doors.....	Page 8
2.8. Control.....	Page 9
2.9. Safety elements.....	Page 11
3. Dimensions for installation.....	Page 13
3.1. Minimum shaft dimensions in elevation.....	Page 13
3.2. Minimum shaft dimensions in plan view. Model EHM-1500	Page 15
3.3. Minimum shaft dimensions in plan view. Model EHM/DC	Page 17
3.4. Minimum shaft dimensions in plan view. Model EHM/DCL	Page 19

1. General description

1.1. Application

Lifting platform intended for the vertical transport of goods and which also allows the people responsible for the handling of such goods to travel with the platform. The lifting platform is designed for operation between defined landing levels and intended for use by authorised and instructed users.

It is suitable for various applications in the industry and services sectors, and it is appropriate for the transport of palletised goods, even together with the appropriate means for their handling, both manual and automatic such as hand pallet jacks and forklifts.

The lifting platform is designed for permanent installation in a building, with a space physically separated from the surroundings (enclosed shaftway) and with doors on all accesses to the shaftway.

Model
EHM-1500

The car dimensions and the load rating of the lifting platform are appropriate for the loading and unloading with both manual and automatic pallet jacks.

Model
EHM/DC
EHM/DCL

Lifting platforms with larger car dimensions and larger permissible load ratings; this makes these models suitable for the loading and unloading of the goods with forklifts.

1.2. Regulations

The lifting platform complies with the 2006/42/EC Machinery Directive and may therefore be commercialized in all countries in the European Union. The lifting platform is classified as belonging to the category of devices for the lifting of persons or of persons and goods involving a hazard of falling from a vertical height of more than three metres. Taking this classification into consideration, the procedure for the assessment of conformity with a full quality assurance system is applied.

1.3. Characteristics

Rated load

Depending on the model, the following load ratings are available:

Model	EHM-1500	EHM/DC	EHM/DCL
Q (kg)	1000		
	1500		
	2000	2000	2000
		3000	3000
		4000	
		5000	

The rated load of the lifting platform includes both the weight of the goods to be transported and of any mechanical means used for the handling of the goods.

Rated speed

0.15 m/s

Stops

2, 3 or 4 stops

Travel

Up to 12 meters.

Type of drive

Indirect acting hydraulic drive.

Electric characteristics

There are two independent circuits in the lifting platform: a main circuit and an additional circuit for the lighting both of the car and of the shaft. Each of these circuits requires an independent supply with the following characteristics.

Main circuit: 400 V ± 5% three-phase 50/60 Hz (other voltages available). The maximum line current consumption at full load may reach the following values:

Q (kg)	Current (A) ⁽¹⁾
1000	12
1500	15
2000	18
3000	22
4000	28
5000	31

⁽¹⁾ For 400 V supply voltage

Lighting circuit: 230 V ± 5% single-phase 50/60 Hz (other voltages available). Depending on the car dimensions and the travel of the lifting platform the power draw may reach 1400 W.

2. Detailed description

2.1. Drive

Indirect acting hydraulic drive with simple cylinders and with chain suspension with a 2:1 relation. Depending on the model, the lifting platform can have one or two guiding columns; the cylinder, the sling and the suspension system are supplied preassembled on these columns.

Model
EHM-1500

One single guiding column installed on one of the sides of the car, with only one integrated cylinder and suspension system.

Model
EHM/DC
EHM/DCL

Double guiding column, each with an independent cylinder and suspension system. In the EHM/DC model the columns are installed facing one another, with a column on each side of the car; in the EHM/DCL model, the columns are installed side by side on the same side of the car.

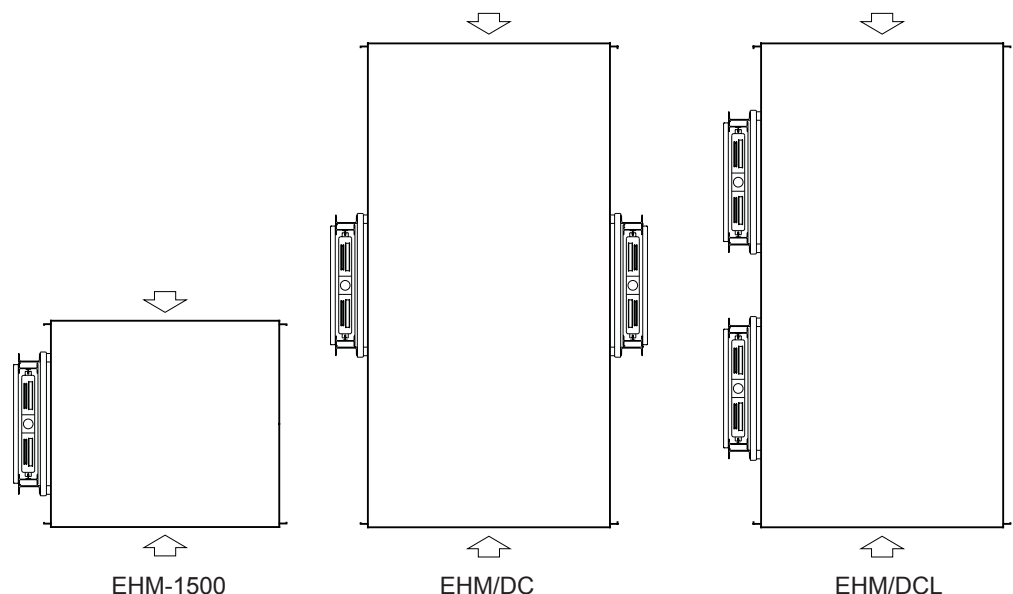

Cylinder

Simple cylinders with inner hydraulic buffering, with rupture valve, oil leakage collection in the cylinder head and oil inlet in the lower section of the cylinder; cylinders in diameters 70, 80, 90 or 100 mm depending on the model, load and travel of the lifting platform. For lifting platforms with two cylinders the rupture valves are interconnected to guarantee simultaneous actuation.

Suspension

With two ISO 4347 lifting chains in each of the columns. Depending of the model and the rated load of the lifting platform, the features of the chains are as follows:

Model	Q (kg)	Chains
EHM-1500	1000	2 x ¾" 6x6
	1500	
	2000	2 x 1" 4x4
EHM/DC EHM/DCL	2000	4 x ¾" 6x6
	3000	
EHM/DC	4000	4 x 1" 4x4
	5000	4 x 1" 6x6

Safety system against rupture or slackening of the suspension means with two safety cables in each column, 10 mm in diameter, with a 8x19S-IWRC layout and wires with a 1770 N/mm² resistance.

2.2. Machine

Both the hydraulic power unit and the electric board shall be installed in a closed machine room for the exclusive use of the lifting platform. This machine room shall have a permanent lighting installation and appropriate ventilation.

The lifting platform is foreseen to be installed with the machine room at a maximum distance of 10 m from the oil inlet to the cylinder. Enquire in case of greater distances.

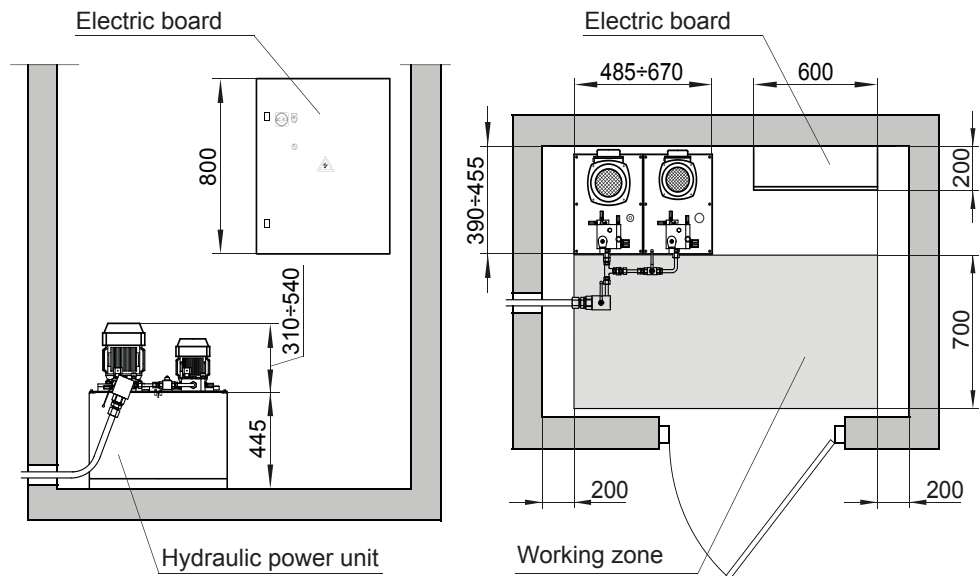

Hydraulic power unit

Two speed hydraulic power unit with a double motor-pump assembly with external motors, gear pumps and two valve blocks. The rated speed of the lifting platform is obtained joining the flow rates of both motor-pump assemblies; with the operation of the smaller assembly a reduced speed is obtained (0.05 m/s) both for the levelling of the car during the re-levelling operation and for the retraction and support of the anti-creep device system (see "2.8 Control").

Low noise level hydraulic power unit with continuous helical rotor pumps, available as an option.

Y- Δ motor starting, available as an option.

A pressure gauge with a protection shut-off valve and a non-return valve are included, together with a manual descent push button as an emergency system for the rescue of the load and the attendants. A minimum pressure valve is also included to avoid the slackening of the suspension chains. A return filter with an integrated main shunt-off valve and an additional individual shunt-off valve for the small motor-pump assembly are also included in the hydraulic power unit.

Electric board

Electric board in a metal cabinet with a main switch located on the outside of the door of the cabinet and which is lockable with a padlock. The switch cuts off power to all the circuits except the lighting circuit. A switch for the lighting circuit is also provided, located by the main switch.

2.3. Guiding and installation

Guiding

As means of guiding for the lifting platform, each of the columns consists of a guide assembly made of a soldered structure of IPE160 profiles braced together. The sling of the car moves along this guide assembly, with four metallic rollers that roll along the IPE160 profiles; four additional rollers are included for side guiding, to obtain a proper guiding in case of out of center loading. Two T45 calibrated guides are included in the guide assembly for the guiding of the pulley head.

Depending on the travel, the guide assemblies may be supplied in one or two sections. The guiding structure is supplied with the cylinder, suspension system and car sling already installed; these elements shall be supplied installed on the lower guide section in case the guide is supplied in two sections.

Standard finishing for the guide assembly is painted in epoxy paint, colour blue RAL5017. A finishing with a high resistance to oxidation is available as an option, with a hot galvanising treatment of the soldered guiding structure and of the sling.

Installation of the guides

The guiding columns are foreseen for fixation to the floor of the pit and to the lifting platform shaft walls. To handle the columns during installation, a hook or beam shall be available on the shaft ceiling and located parallel to each guide, in the vertical projection of the cylinder; they shall resist at least 1500 kg.

All the required material for the fixation of the guide assemblies to the shaft wall is supplied, with brackets fixed to the wall with mechanical anchorages and adjustable profiles that are fixed to the guiding structure.

The shaft walls to which the guides are fixed shall be made of structural concrete; the material supplied is appropriate for this type of wall. In case of walls made of hollow brick or other materials, alternative solutions for the fixation of the columns are required, such as the installation of a structure of metal profiles embedded in the wall to which the fixations may be soldered and which can withstand the transmitted reactions, which are indicated in the assembly instructions.

The position of the fixations of the guide rails is also indicated in the assembly instructions; a fixation every 2 m is included, or every meter in case of rated loads equal or larger than 4000 kg. Additional fixations are included at 0.5 m from the upper end of the guide and on both sides of the joint in case of guiding columns supplied in two sections.

2.4. Hydraulic installation

Flexible double metal mesh hydraulic hoses, individually tested for pressure together with the corresponding connectors; the result of the test is marked on the pipe.

Oil inlet in the lower section of the cylinder through the rupture valve that acts as protection against the rupture of the pipes.

2.5. Electric installation

The electrical installation of both the platform and the shaft are supplied pre-wired and with plug-in terminals to connect to the electric board and to the connection box located under the car floor.

The shaft lighting (optional on request) is supplied with the lights and the pit switch pre-wired and with a plug-in connector for connection with the electric board.

Waterproof electrical installation optional on request. In this case the installation is not pre-wired and with plug-in connections, but with waterproof connection boxes that require wiring during installation.

2.6. Car

Floor

The floor of the car is a soldered assembly that consists of a grid made of hot rolled tubes and/or profiles, together with a threaded plate as the loading surface. In the double columns models and depending on the dimensions of the platform, the floor may be supplied in one or two sections.

Floor finishing with epoxy paint colour blue RAL5017.

Available on request is a floor with a stainless steel threaded plate or an aluminium diamond plate. Also available on request is a finishing with a high resistance to oxidation with a hot galvanising treatment for the soldered structure of the floor (together with the galvanising of the guide assembly and of the sling).

Walls

Walls made of galvanised steel plate.

Stainless steel protection available on request (optional).

On the lower surface of the car walls, protection tubes against crashes during the handling of the goods are installed. Three rows of protections are supplied, made of rectangular 80.40 galvanised steel tubes, installed at an appropriate height taking the foreseen use into consideration (see "3.1. Minimum shaft dimensions in elevation").

Ceiling

Galvanised steel plate modules.

Stainless steel modules available on request.

Lighting

With lights with a 230 mm diameter; the lights are of the downlight type with compact fluorescent lamps of 2x18W and an electronic ballast. Depending on the car dimensions, between one and four lights may be installed embedded in the car ceiling modules.

Dimensions

Model	Width A (mm)	Depth B (mm)	Height H (mm)
EHM-1500	1500 ÷ 2800	800 ÷ 2000	2000 ÷ 2500
EHM/DC	1200 ÷ 2800	1600 ÷ 6000	
EHM/DCL	3000 ÷ 5500	800 ÷ 2500	

The maximum car surface is determined by the rated load according to the ratio 350 kg/m², as detailed below:

Q (kg)	A·B (m ²)
1000	2.9
1500	4.3
2000	5.7
3000	8.6
4000	11.4
5000	14.3

A series of different recommended combinations for size and load are shown below, for some frequent uses of the lifting platform with palletised loads.

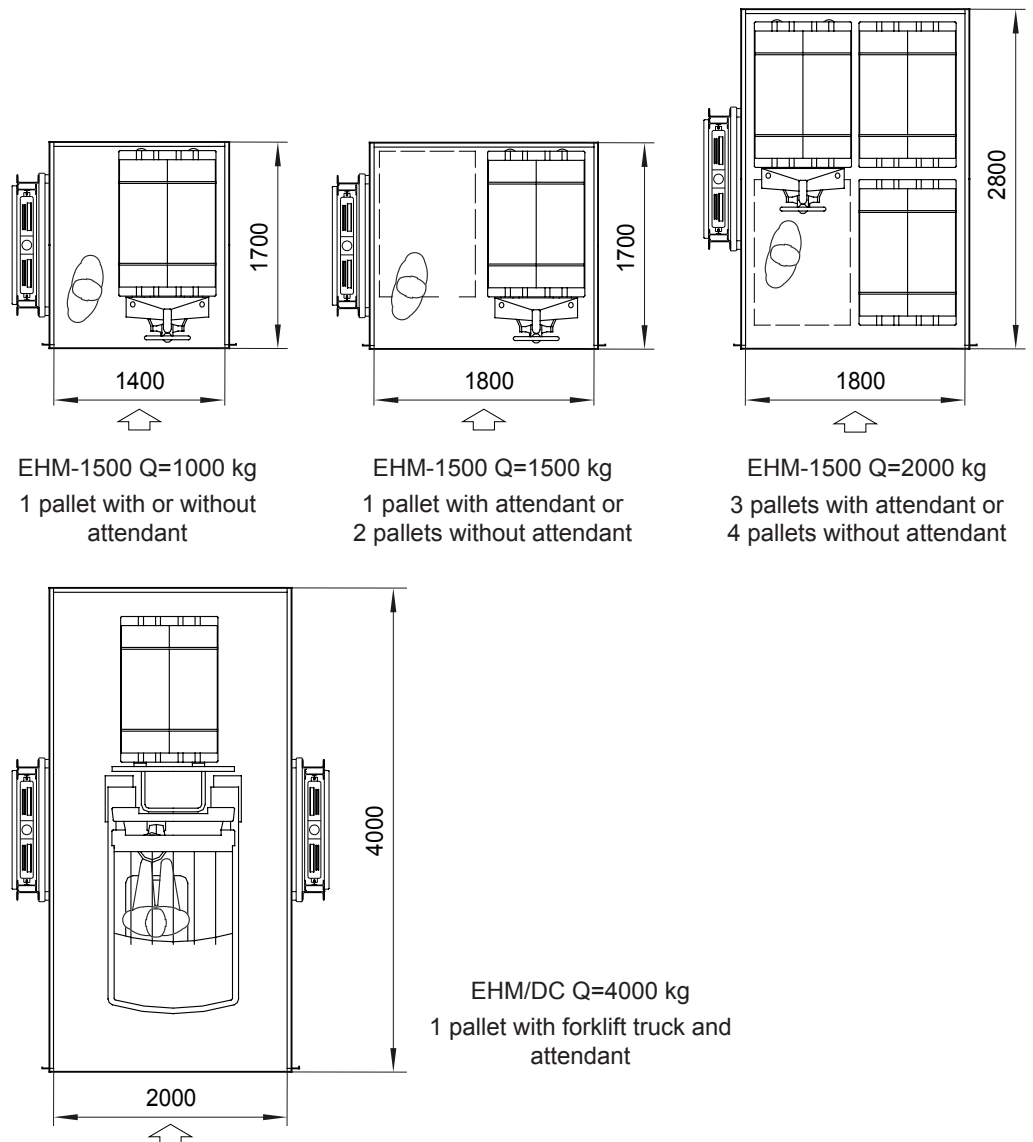

Accesses 1 or 2 at 180°.

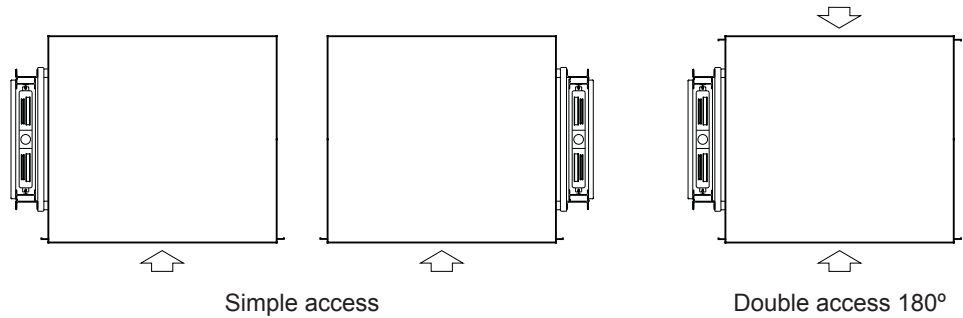

2.7. Landing doors

Types Two models are available: swing doors and slat sliding doors. Both models include electric actuated locks.

Swing door Manual swing door, available both in one or two leaf versions. The doors are completely made of steel plate, with solid surface leaves without spyholes, external steel hinges and with an opening angle of 180°. Fire resistant doors, with a E120 rating according to the EN 81-58 standard.

Finishing Painted with epoxy-polyester paint in colour grey RAL7035 as standard finishing.
 Available on request with finishing painted in other colours in the RAL chart.
 Available on request with finishing with stainless steel plate.

Dimensions Clear height (HL): between 2000 and 2500 mm.
 Clear opening (PL): between 700 and 1250 mm for single leaf doors
 between 1000 and 2800 mm for double leaf doors

Hand Swing single leaf doors.

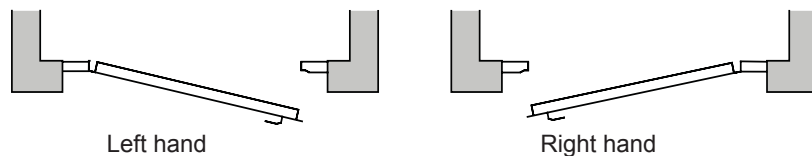

Installation Single leaf doors are supplied completely assembled, with the leaf already bolted to the soldered frame. Two leaf doors are supplied disassembled; they consist of a disassembled frame made of a lintel, two jambs and a sill; the leaves are bolted to this frame. The installation of both the single and double leaf models on the wall is foreseen in such a way that the sill is embedded in the edge of the floor so that there is an even surface with no protrusions towards the inside of the shaft of the lifting platform on the side of the entrances (see "3.1. Minimum shaft dimensions in elevation"). All the required material for the fixation of the doors to the shaft walls with supports and anchorages is supplied.

Slat sliding doors

Manual sliding doors which open taking advantage of the space between the car and the shaft wall; available in versions with a single side opening leaf or double central opening leaves.

The leaf is made of 40 mm thick aluminium slats, with no intermediate hinges and slats which fit into one another perfectly due to their shape, thus obtaining great resistance and uniformity when closed and making substitution of slats in case of repair an easy task.

Fire resistant doors according to the EN 81-58 standard with slats made of steel plate, available as an option.

Automatic operation available as an option, by means of a toothed drive belt actuated by a direct current gearmotor controlled by an electronic circuit with a microprocessor.

Finishing Standard finishing of the doors is painted with epoxy-polyester paint in colour grey RAL7035.

Finishing with paint in other colour of the RAL chart available as an option.

Dimensions Clear height (HL): between 2000 and 2500 mm
 Clear opening (PL): between 950 and 2800 mm for single leaf doors
 between 1500 and 2800 mm for double leaf doors

Hand Single leaf sliding door.

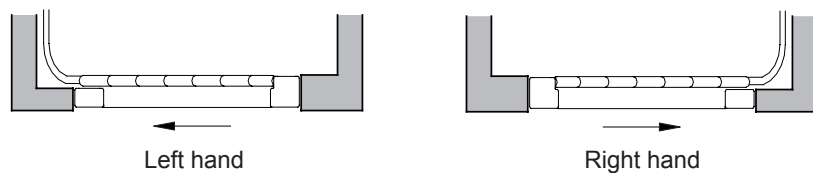

Installation The installation is foreseen in such a way that the sill is embedded in the edge of the floor to that there is an even surface with no protrusions towards the inside of the shaft of the lifting platform on the side of the entrances (see "3.1. Minimum shaft dimensions in elevation"). All the required material for the fixation of the doors to the shaft walls with supports and anchorages is supplied.

With the automatic drive option all the elements of the motorised drive and the control are accesible from the landing level through the lintel cover.

2.8. Control

Operation

The lifting platform has been designed in such a way that the car movements may be controlled from the different landing levels, without the need for the operator to travel with the load. This allows for maximum optimization of the car surface and also enables a faster loading-travel-unloading sequence; this means of operation requires the presence of an operator at each landing level or that the same operator moves between landing levels by other means.

Additionally, the lifting platform also allows the movements of the car to be controlled from inside the car. In this way, the operator may travel together with the load so that a single operator may carry out the complete sequence.

Controls

The lifting platform has a control push button panel at each landing level and an additional control push button panel inside the car.

Landing push button panels Push button panels are designed to be embedded at each landing level, either on the wall or on the frame of the landing doors. Push button panels with flush mounting controls and waterproof on the outer face mounted on a stainless steel plate.

The following elements are included in the push button panels:

- Key enabling switch for restriction of use.
- Call/send push button panels for each landing level.
- Green car present light indicator.
- Red car occupied light indicator.
- With the option of slat sliding doors with automatic drive, an additional push button to open doors and another push button to close doors.

The push buttons of one or several landings may be substituted for key switches to restrict access to the corresponding landing levels.

Car push button panel

Integrated in the central removable car panel on the side of the guide assembly column; embedded in the panel with relation to the car surface to avoid impact to the control elements during the handling of the load; the control elements are of the flush mounting type.

The following elements are included in the push button panel:

- Key enabling switch for restriction of use.
- Push buttons for each landing level, with light indication of the position of the car.
- Alarm push button.
- Emergency lighting integrated in the alarm push button.
- Emergency stop push button with light indication of activation.
- Light and acoustic overload indicator.
- Illuminated selector switch for the control of the anti-creep system (only with the optional anti-creep system).

Main control features

- Control based on a programmable logic controller.
- Movement of the car with hold to run control from the car push button panel, and automatic (not hold to run) from the landing push button panels.
- Priority of the car commands over the landing push button panel commands.
- Landing detection with magnetic switches.
- Movement of the car is subject to the landing doors being closed and locked and to the light curtain not being interrupted.
- Car light timing with automatic turn-off for energy consumption reduction.
- With the optional automatic sliding doors, self adjustment of the travel and operation parameters of the doors.

Re-levelling

When there is a loss in level of the car during loading or unloading of the goods, or due to a long inactivity period, the car will automatically regain the landing level at reduced speed; this is achieved by activating the small motorpump assembly in the hydraulic power unit. The system shall carry out this releveling movement even with open doors. This option is included in all lifting platforms which do not include the anti-creep system option (see following section).

**Anti-creep system
(optional)**

The anti-creep system includes a series of mechanical devices aimed at preventing loss of car level during the loading and unloading operations, in order to guarantee a perfect levelling with the landing level. It consists of a series of retractable rods (latches) that rest on support pieces installed on the guide assemblies. When the movement of the car is commanded from the landing levels, the anti-creep system operates in a fully automatic mode. When the operator controls movement from the inside of the car, the anti-creep system is also controlled from the car push button panel.

**Operation of the
automatic doors
(optional)**

With the optional automatic slat sliding doors, operation of the door is controlled from the landing levels with the corresponding push buttons for the opening and closing of the doors. When movement is controlled from inside the car, the door shall close automatically when a movement is commanded, and they shall open automatically upon arrival at a landing level.

2.9. Safety elements

Among the safety measures of the lifting platform, the following may be highlighted:

General

- Rupture valve as a safety measure against free fall due to rupture of piping.
- Safety cables as a safety measure against free fall due to breakage of the suspension chains.
- Electric control of breakage or slackening of the chains.
- Doors with electric control both of closure and locking of the door.
- Re-levelling with open door system or anti-creep device system as a safety measure against car creepage.
- Upper final limit switch.
- Control of the maximum motor and electrovalve electric supply time.

Use

- Light curtain as safety measure against trapping hazards in the loading area. The curtain also aids during the loading of the car to prevent the load from protruding from the edge of the car, including an acoustic signal when the curtain is interrupted. Additionally it prevents the automatic doors from closing when the curtain is interrupted.
- With the automatic door option, system for the limitation of the closing force of the landing doors with a reopening system in case an obstacle is detected.
- Load control system with pressure transducer.
- Emergency stop push button in the car.
- Descent operation with battery supply to the landing situated immediately below the present position in case of power supply failure, commanded from the car. Automatic opening of the doors on arrival at the landing (only with the optional automatic sliding doors).
- Acoustic alarm push button inside the car to warn an external assistance in case of being trapped inside the car due to breakdown.
- Manual descent push button in the hydraulic power unit for rescue operations in case of breakdown.
- Manual opening on the doors with triangular emergency key for rescue operations in case of breakdown.

Maintenance

- Maintenance operations from the pit and from inside the car through the removable central panel where the push button panel is installed, and through several removable peepholes which face the guiding column/s.
- System for pit access detection for maintenance operations which is activated when the opening of the lower landing level door with the emergency triangular key is detected, and which prevents the normal operation of the lifting platform.
- Movable safety blocking device to guarantee the necessary safety spaces for the maintenance operations in the pit. The device is manually activated and includes an acoustic signal that warns of access to the pit until the device has been activated.
- Stop push button in the pit to prevent the car movement before the mobile blocking device is activated.
- Circuit breakers in the control panel, one for protection of the main circuit and another for the lighting circuit, as an additional safety against indirect contacts.

3. Dimensions for installation

3.1. Minimum shaft dimensions in elevation

Model EHM-1500

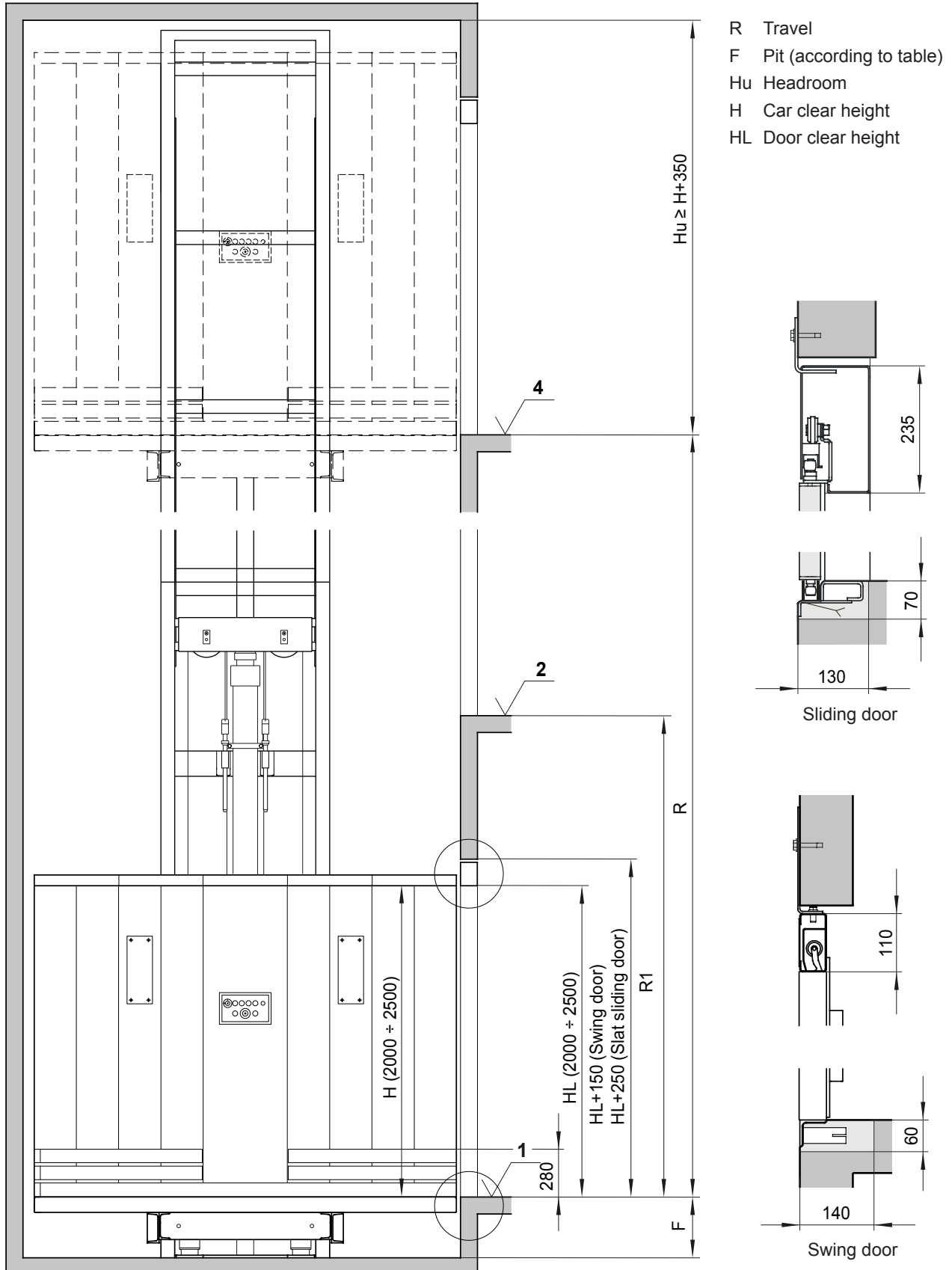

Model EHM/DC

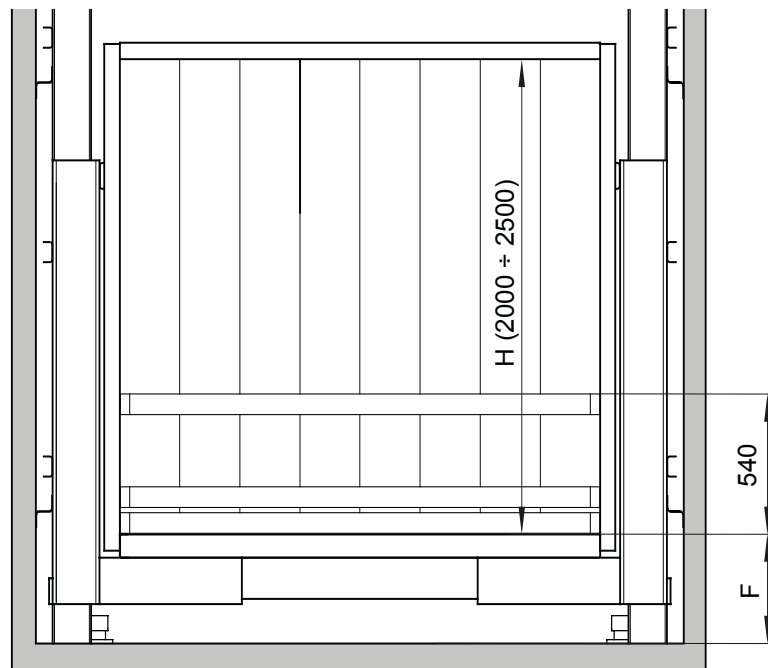

- F Pit (according to table)
- H Car clear height
- HL Door clear height

Model EHM/DCL

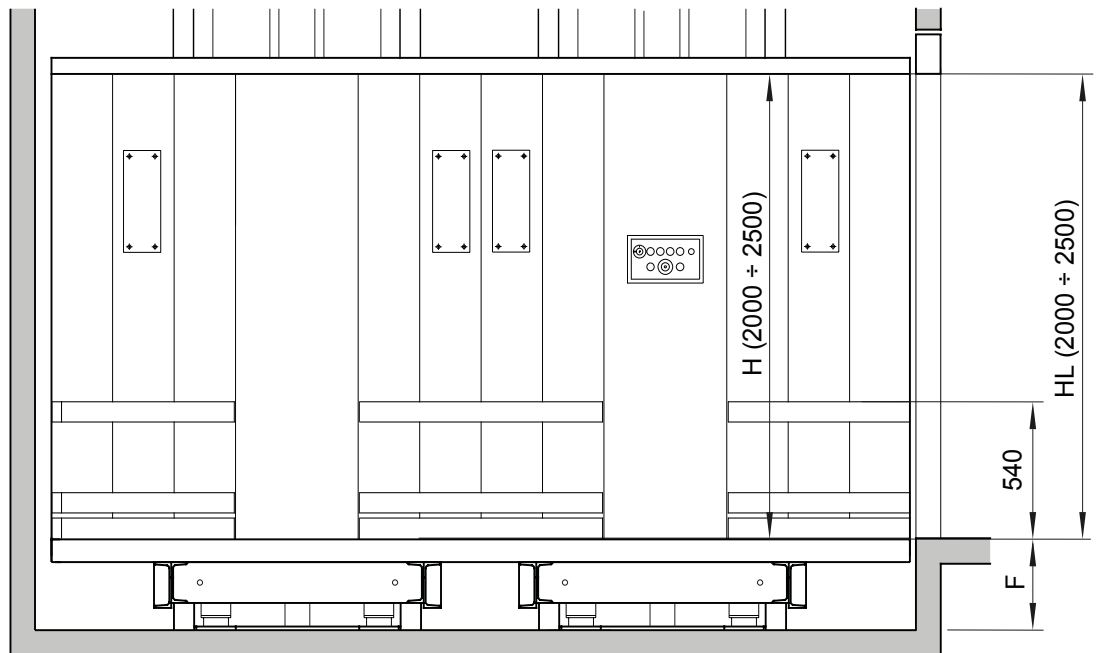

Pit dimensions

Model	Options	Minimum pit (mm)	Maximum pit (mm)
EHM-1500	Without anti-creep	350	1500
	With anti-creep	400	
EHM/DC	$Q \leq 3000$	400	1700
	$Q \geq 4000$	450	
EHM/DCL	-	450	

3.2. Minimum shaft dimensions in plan view. Model EHM-1500

Manual swing door

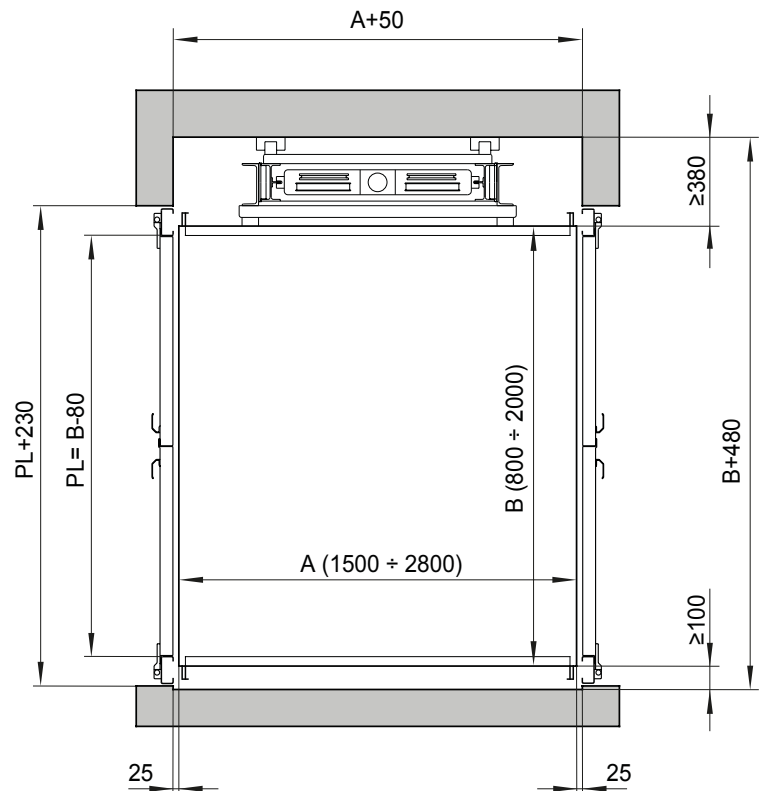
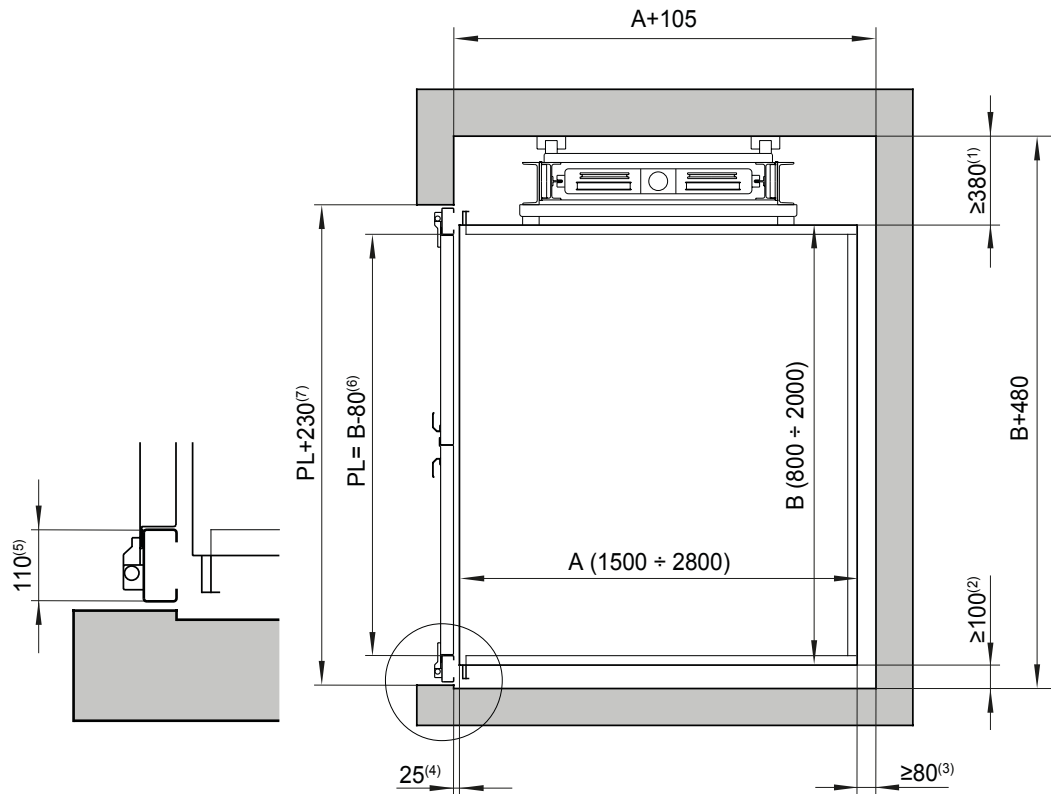

A Car width

B Car depth

PL Clear opening

(1) Minimum distance for guide installation (maximum 580)

(2) Minimum car-wall distance for the side adjacent to the entrance

(3) Minimum car-wall distance

(4) Distance between entrance and car

(5) Door frame width

(6) Recommended

(7) Gap in wall for door installation

Single leaf slat sliding door

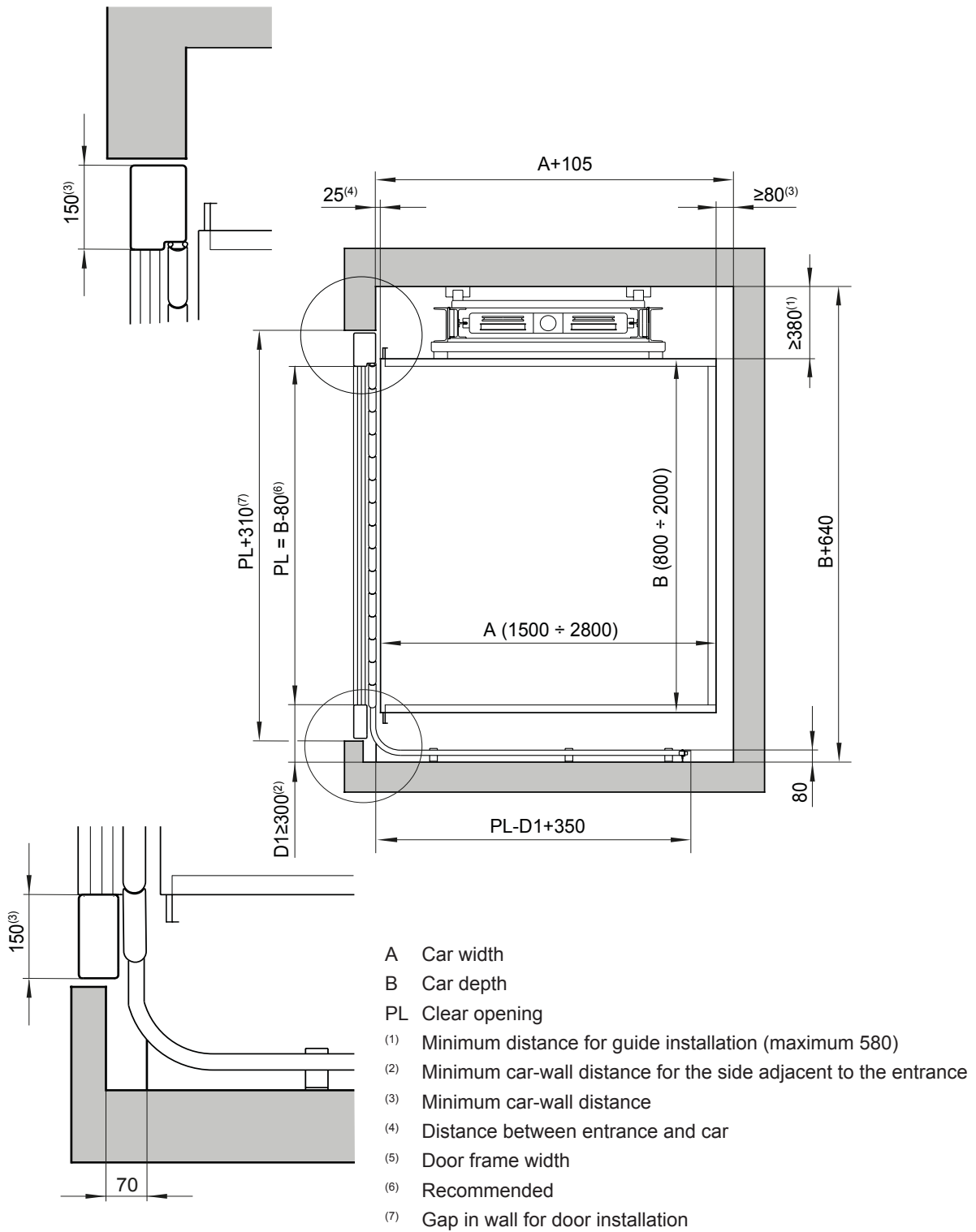

3.3. Minimum shaft dimensions in plan view. Model EHM/DC

Manual swing door

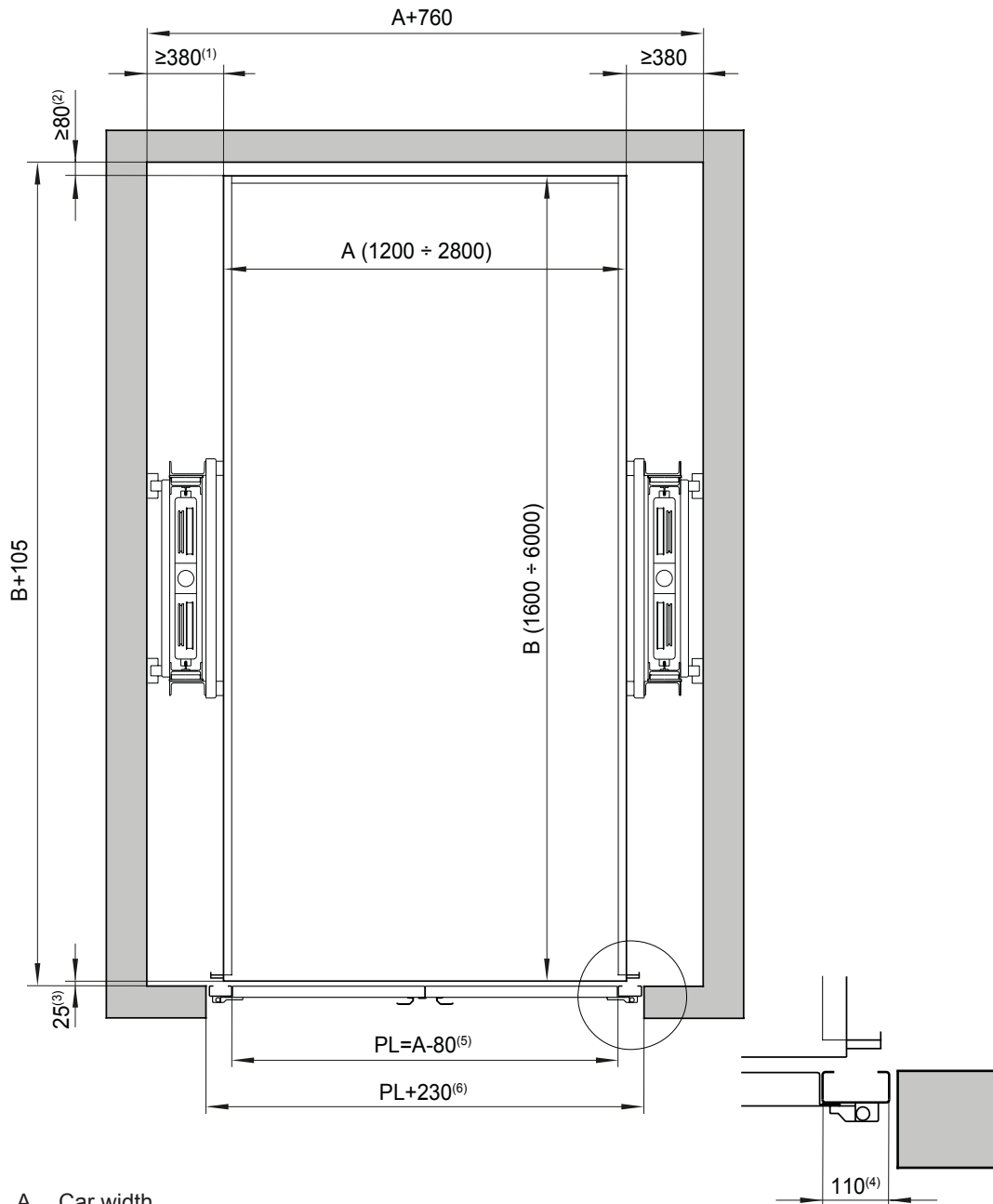

A Car width

B Car depth

PL Clear opening

(1) Minimum distance for guide installation (maximum 580)

(2) Minimum car-wall distance

(3) Distance between entrance and car

(4) Door frame width

(5) Recommended

(6) Gap in wall for door installation

Two leaf slat sliding door

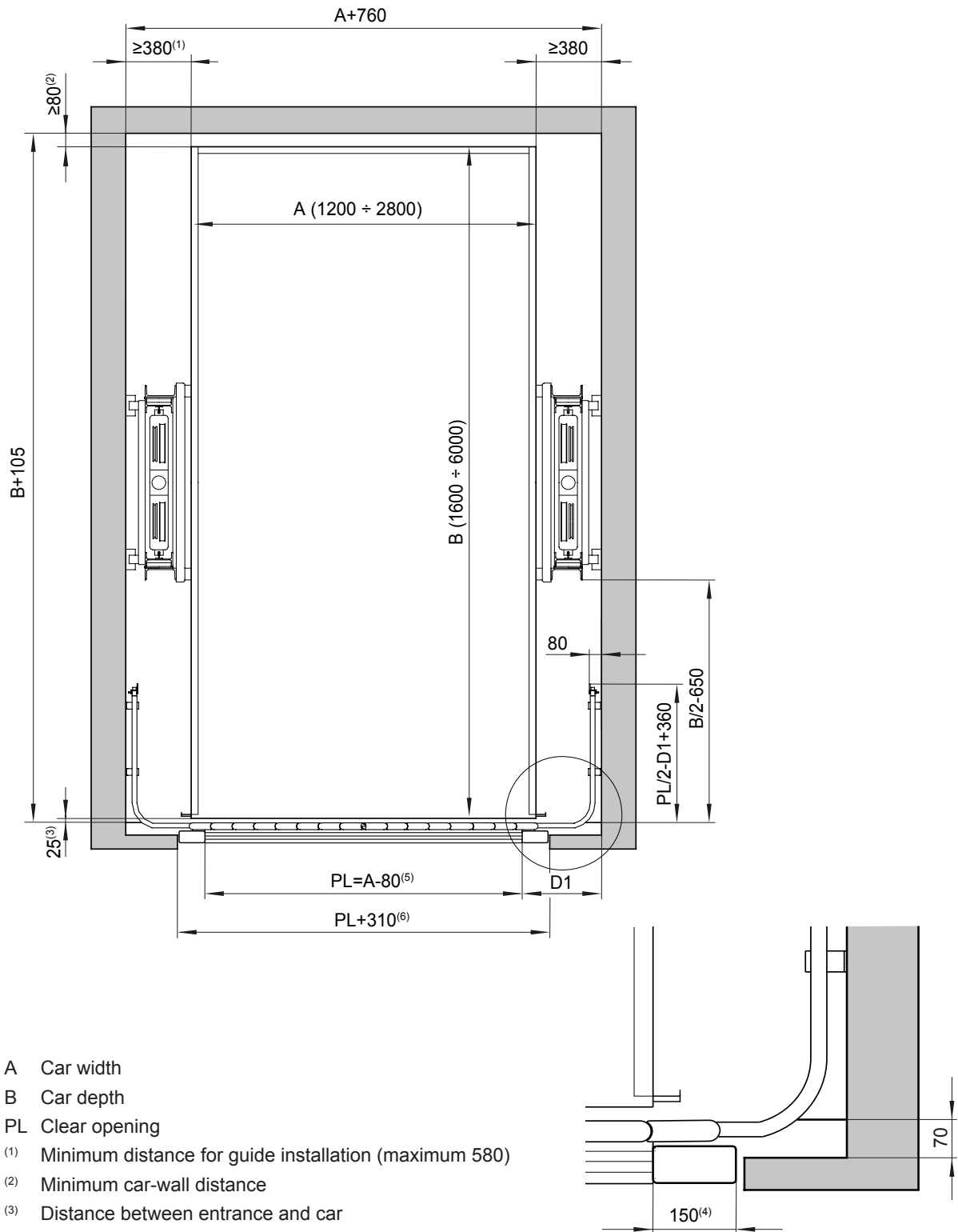

- A Car width
- B Car depth
- PL Clear opening
- (1) Minimum distance for guide installation (maximum 580)
- (2) Minimum car-wall distance
- (3) Distance between entrance and car
- (4) Door frame width
- (5) Recommended
- (6) Gap in wall for door installation

3.4. Minimum shaft dimensions in plan view. Model EHM/DCL

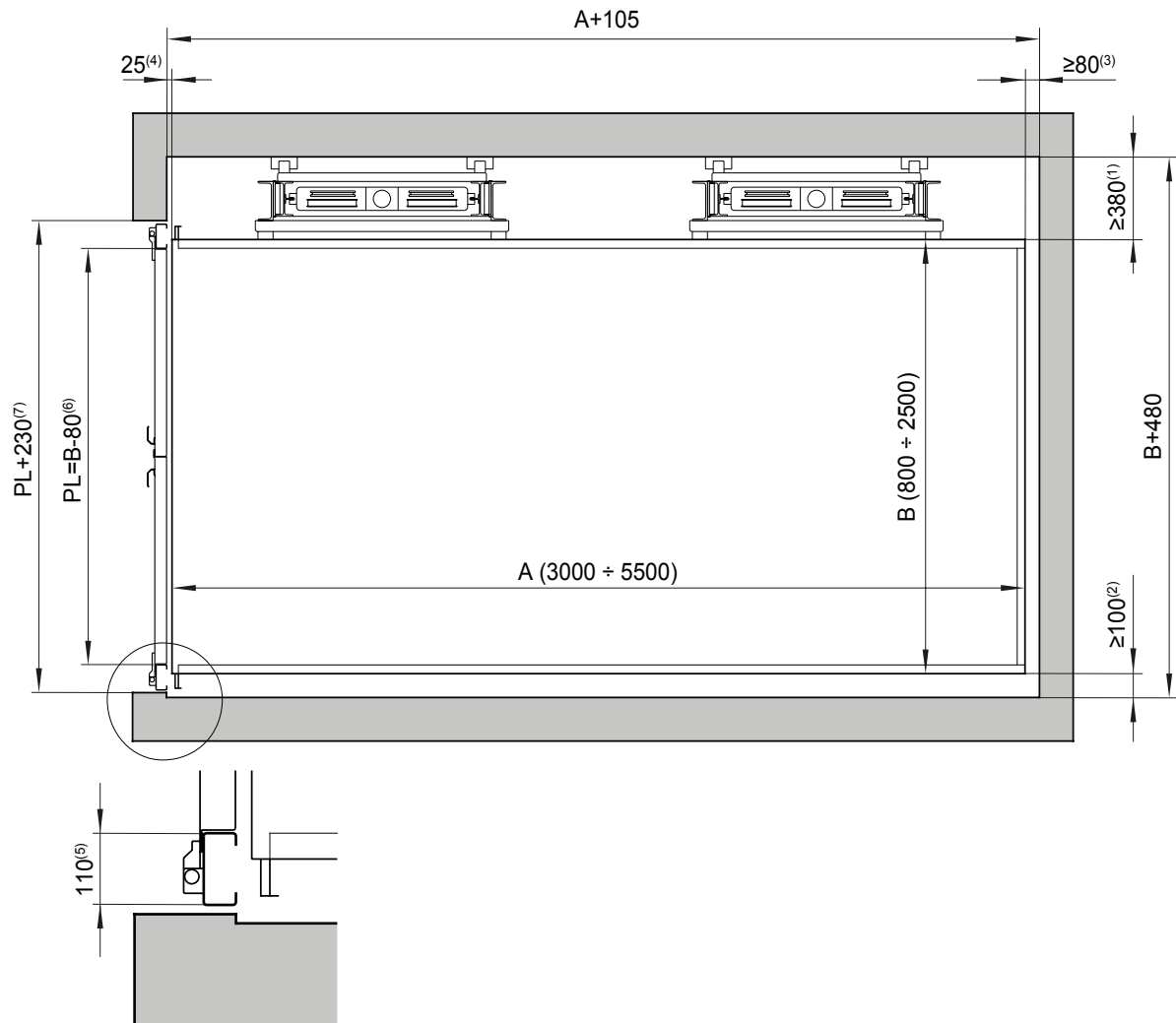

A Car width

B Car depth

PL Clear opening

(1) Minimum distance for guide installation (maximum 580)

(2) Minimum car-wall distance for the side adjacent to the entrance

(3) Minimum car-wall distance

(4) Distance between entrances and car

(5) Door frame width

(6) Recommended

(7) Gap in wall for door installation

Hidral, S.A.

Polígono Industrial PARSI, Calle 7, 3
41016 - Sevilla (Spain)
t.+34 954 514 500 f.+34 954 677 633
www.hidral.com